

HIGH-TEMP RADIAL INSERT BALL BEARINGS FOR LOW SPEEDS



High - Temperature Radial Insert Ball Bearings and Housing Units

Version: 10/2023

Every care has been taken to ensure the correctness of the information contained in this document but no liability can be accepted for any errors or omissions. Subject to change without prior notice.

GMW Radial Insert Ball Bearings and housing units

- Radial clearance C5
- Riveted sheet steel cage
- Basic corrosion protection due to manganese phosphate coating (according to EN ISO 9717)

GMW Radial Insert Ball Bearings can be delivered with housing or as unit including one of the following housing options:

- Plummer block housing (UCP)
- Two-bolt flanged housing (UCFL)
- Four-hole flanged housing (UCF).

High-temp Radial Insert Ball Bearings for Low Speeds

GMW High-temp Radial Insert Ball Bearings guarantee long operating lifetime and reduced maintenance costs at **high temperatures and low speeds**.

Depending on the used lubricant, GMW High-temp Radial Insert Ball Bearings are suitable for **temperatures up to 350°C**.

The increased radial clearance, which is a multiple of the clearance C5, works as a **compensation for temperature-induced deformations of the production goods**.

Riveted sheet steel cage

provides high stability at low friction

Manganese phosphate coating (according to EN ISO 9717) ensures increased protection against corrosion, good adhesion of lubricants and better runability.

GMW offers three lubricants for High-temp Radial Insert Ball Bearings, which can be differentiated as follows:

- **HT1**

Temperature range:	< 350°C
Type Lubrication:	Special grease (MoS2)
Clearance:	(Multiple of C5)
Maintenance after:	4 – 10 Months

- **HT2**

Temperature range:	< 280°C
Type Lubrication:	Special grease (PFPE)
Clearance::	(Multiple of C5)
Maintenance after:	8 – 14

Radial Insert Ball Bearings UC2xx

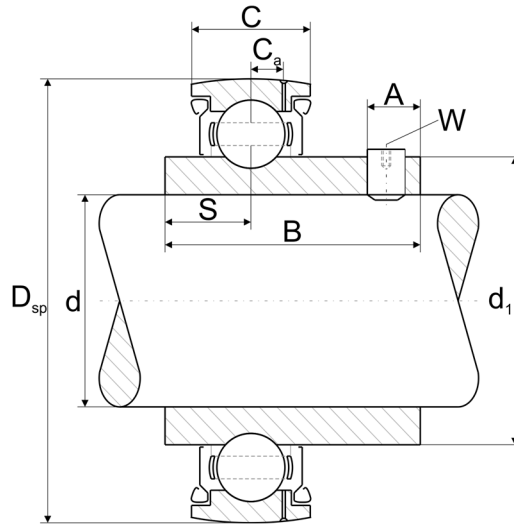

GMW	Dimensions									Load Ratings		Max. Speed	Weight
Code	d Dsp		C	B	S	d1	Ca	A	W	C0r	Cr	HT	≈ [kg]
	[mm]	[mm]	[mm]	[mm]	[mm]	[mm]	[mm]	[mm]	[mm]	[kN]	[kN]	[min ⁻¹]	
UC204	20	47	17	31,0	12,7	27,56	4,2	5	3	6,6	12,8	140	0,15
UC205	25	52	17	34,1	14,3	33,83	4,2	5	3	7,8	14,0	130	0,20
UC206	30	62	19	38,1	15,9	40,20	5,0	5	3	11,3	19,5	110	0,31
UC207	35	72	20	42,9	17,5	46,84	5,7	7	4	15,3	25,5	90	0,47
UC208	40	80	21	49,2	19,0	52,27	6,2	8	4	19,8	32,5	80	0,62
UC209	45	85	22	49,2	19,0	57,91	6,3	8	4	20,4	32,5	80	0,69
UC210	50	90	24	51,6	19,0	62,84	6,5	10	5	23,2	35,0	70	0,80
UC211	55	100	25	55,6	22,2	69,77	7,0	10	5	29,0	43,5	60	1,07
UC212	60	110	27	65,1	25,4	76,48	7,4	10	5	36,0	52,0	50	1,49
UC213	65	120	28	65,1	25,4	80,85	8,2	12	6	40,0	57,0	50	1,73

(Remark: The weight applies for the bearing only without lubricant and shields)

Housing Units UCP2xx

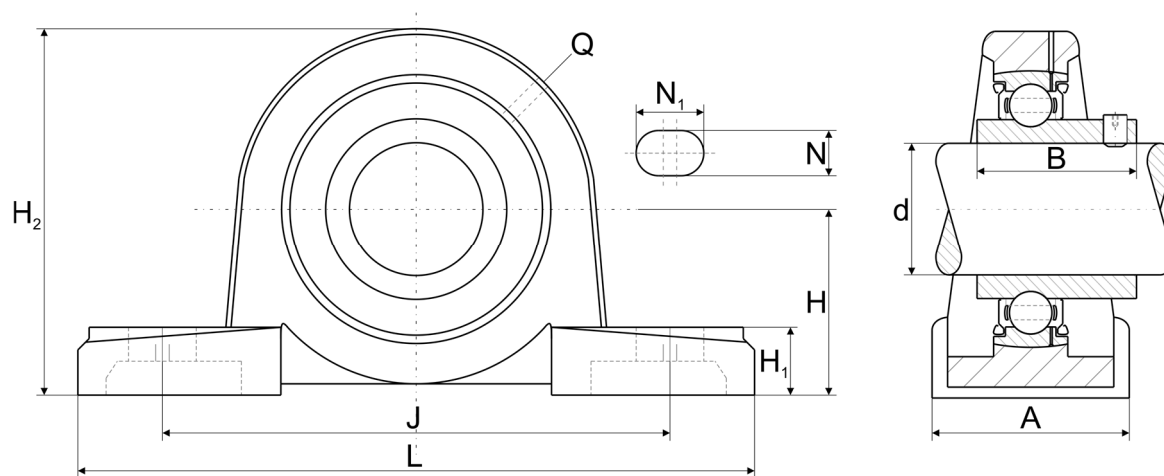

GMW	Dimensions											Weight
Code	d	H	J	L	A	H1	H2	N	N1	B	Q	≈ [kg]
	[mm]	[mm]	[mm]	[mm]	[mm]	[mm]	[mm]	[mm]	[mm]	[mm]		
UCP204	20	33,3	95	127	38	14	65	13	19	31,0	M6	0,65
UCP205	25	36,5	105	140	38	15	71	13	19	34,1	M6	0,79
UCP206	30	42,9	121	165	48	17	83	17	21	38,1	M6	1,29
UCP207	35	47,6	127	167	48	18	93	17	21	42,9	M6	1,55
UCP208	40	49,2	137	184	54	18	98	17	21	49,2	M6	1,84
UCP209	45	54,0	146	190	54	20	106	17	21	49,2	M6	2,20
UCP210	50	57,2	159	206	60	21	114	20	25	51,6	M6	2,77
UCP211	55	63,5	171	219	60	23	126	20	25	55,6	M6	3,41
UCP212	60	69,8	184	241	70	25	138	20	25	65,1	M6	4,62
UCP213	65	76,2	203	265	70	27	151	25	27	65,1	M6	5,57

(Remark: The weight applies for the bearing only without lubricant and shields).

Housing Units UCFL2xx

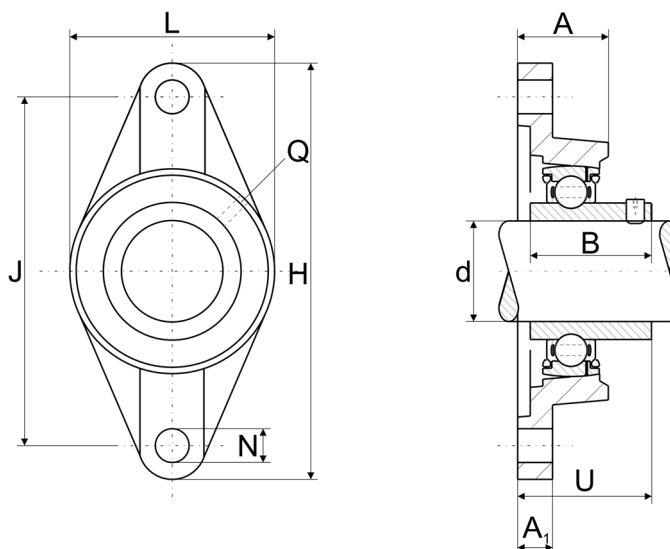

GMW Code	Dimensions										Weight ≈ [kg]
	d [mm]	H [mm]	J [mm]	L [mm]	A [mm]	A1 [mm]	N [mm]	B [mm]	U [mm]	Q	
UCFL204	20	113	90	60	25,5	12	12	31,0	33,3	M6	0,42
UCFL205	25	130	99	68	27	15	16	34,1	35,8	M6	0,64
UCFL206	30	148	117	80	31	14	16	38,1	40,2	M6	0,88
UCFL207	35	161	130	90	34	16	16	42,9	44,4	M6	1,21
UCFL208	40	175	144	100	36	16	16	49,2	51,2	M6	1,48
UCFL209	45	188	148	108	38	18	19	49,2	52,2	M6	1,95
UCFL210	50	197	157	115	40	18	19	51,6	54,6	M6	2,23
UCFL211	55	224	184	130	43	20	19	55,6	58,4	M6	2,87
UCFL212	60	250	202	140	48	20	23	65,1	68,7	M6	3,96
UCFL213	65	258	210	155	50	24	23	65,1	69,7	M6	4,69

(Remark: The weight applies for the bearing only without lubricant and shields).

Housing Units UCF2xx

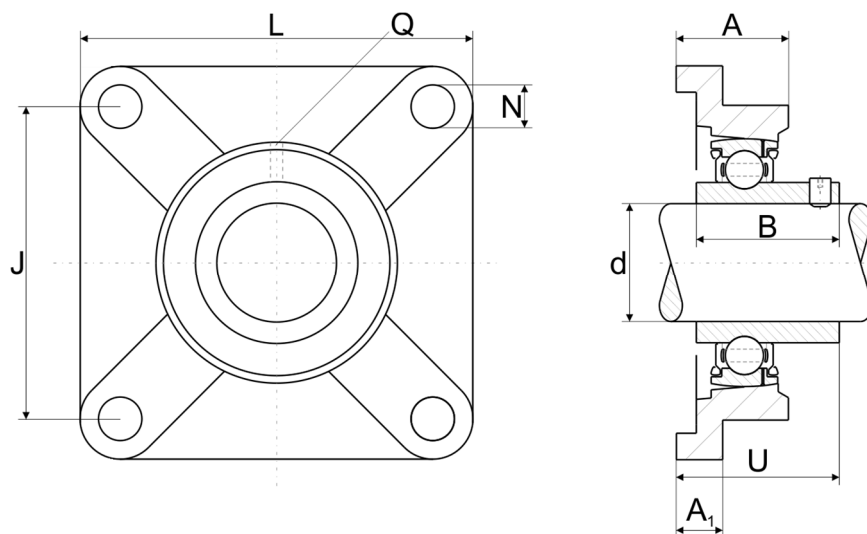

GMW	Dimensions									Weight
Code	d	J	L	A	A1	N	B	U	Q	≈ [kg]
	[mm]	[mm]	[mm]	[mm]	[mm]	[mm]	[mm]	[mm]		
UCF204	20	64	86	25,5	12	12	31,0	33,3	M6	0,57
UCF205	25	70	95	27	14	12	34,1	35,8	M6	0,85
UCF206	30	83	108	31	14	12	38,1	40,2	M6	1,11
UCF207	35	92	117	34	16	14	42,9	44,4	M6	1,50
UCF208	40	102	130	36	16	16	49,2	51,2	M6	1,91
UCF209	45	105	137	38	18	16	49,2	52,2	M6	2,30
UCF210	50	111	143	40	18	16	51,6	54,6	M6	2,56
UCF211	55	130	163	43	20	19	55,6	58,4	M6	3,31
UCF212	60	141	175	48	20	19	65,1	68,7	M6	4,25
UCF213	65	149	187	50	20	19	65,1	69,7	M6	4,91

(Remark: The weight applies for the bearing only without lubricant and shields).